

Montage / Profilbearbeitung

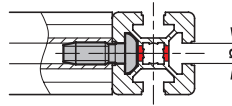
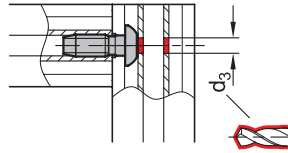
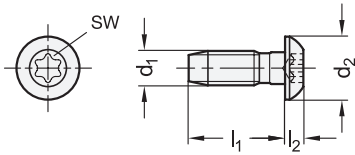

4 Form

A ohne Abdeckkappe

Verwendung

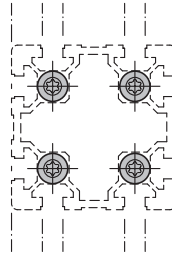
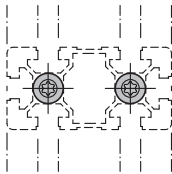

1 n	2 d ₁ Gewinde selbstformend	3 l ₁	d ₂ ≈	d ₃	l ₂ ≈	SW	Anzugsmoment in Nm
8	S 8	25	16	7,8	4,5	T40	25
10	S 12	30	19	9,8	6	T50	35

Ausführung

Stahl

verzinkt, blau passiviert

RoHS



SZ

Zentralschrauben GN 21b verbinden Aluprofile rechtw. Dabei ist nur die Bearbeitung eines Profils nötig. Das Gewinde in der stirnseitigen Profilbohrung wird von der Zentralschraube selbst geformt. Zur Erleichterung der Montage sollte das selbstformende Gewinde geschmiert werden.

Hinweise

GN 10b Aluprofile (Profiltyp leicht)

GN 10b Aluprofile (Profiltyp schwer)

Seite

QVX

QVX

Bestellbeispiel

GN 21b-8 S8 25-A-SZ

1	n
2	d ₁
3	l ₁
4	Form
5	Werkstoff / Oberfläche

Montagehinweise / Profilbearbeitung

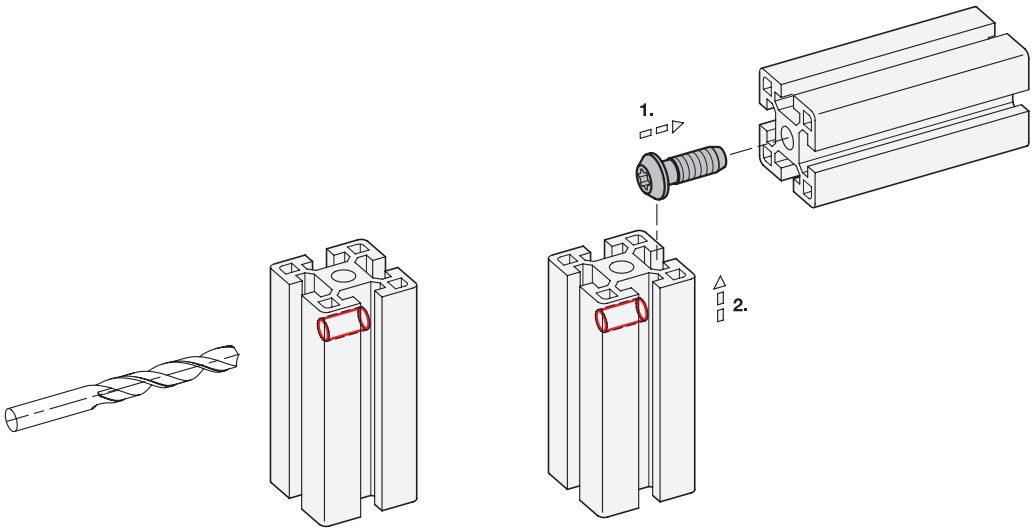

3.1

3.2

3.3

3.4

3.5

3.6

3.7

3.8

3.9

3.10

